



SLEEP WELL  
WE TAKE CARE  
**TOPCOLOR**  
COMPLETE CYCLE DIGITAL PRINTING



BRING **YOUR FILES,**  
CHOOSE **MATERIAL**  
AND **FINISHING**

WE TAKE CARE  
**OF THE REST!**



[www.topcolor.it](http://www.topcolor.it)  
[www.museumhome.it](http://www.museumhome.it)

# INDEX OF DEPARTMENTS

- Administration / Purchasing pag.03
- Project Managers / Customer Contacts pag.04
- Pre-press Photolithography pag.06
- Fine Art / Lambda / TopSec® pag.07
- Durst Large Size Flat Bed Printing pag.10
- Durst Roll to Roll Printing pag.13
- Plotter Cutting pag.16
- Indigo Digital Sheet Printing pag.19
- Plexiglass Work pag.25
- Paper Industry & Packaging pag.26
- Museum Home Fine Art Division (Group Company) pag.28
- Direct UV Lacquering pag.30
- Minor carpentry for Packing/Painting Station pag.31
- Automatic Packer pag.31
- External assembly team pag.32
- Topcolor for EXPO pag.33

## TOPCOLOR DREAM

### Credits:

Durst, HP, Minolta, Zünd, Seiko,  
Esko Kongsberg, Elmag, Flexa, gmg,  
Hahnemüle, Protek.

Produced on the company's premises at,  
Via Toscana 19,  
20090 Buccinasco, Milano  
Tel. +39 02 4886431  
Fax +39 02 45713280

This monograph has been put together by:

President **Claudio Marchesi**  
Director **Luca Rossi**  
Art director **Renè Caruso**  
Graphics **Roberto Davì**  
Photography **Federica Maggi**  
Editor **Lorenzo Carreri**  
Copywriter **Susanna Forloni**  
Photolithography **Topcolor Dream**  
Digital Printing **Topcolor Dream**

# ADMINISTRATION PURCHASING



**Mariangela Brandinali**

Head of Administration  
with Topcolor since 1982



Michela Ambrosini



Paola Vanni

Since 1972 **TOPCOLOR** has been the ideal partner for advertising agencies and media, photographers, booth installers, event organisers, and for any enterprise that demands the best new technologies available today for its images.

19**72** 73 74 75 76 77 78 79 1980  
81 82 83 84 85 86 87 88 89  
1990 91 92 93 94 95  
96 97 98 99  
00 01 02 03  
04 05 06 07  
08 09 10 11  
12 13 14  
15 20**16**.....



Plant in Via Toscana 19 Buccinasco Milan, 5000 square meters + loft (among the largest in Italy)



# The **STRENGTH** of the **COMPANY**

Our technical and commercial team oversees your projects from start to end, discussing all the technical aspects with you to come up with the best possible solution.

Their skills and dedication to the customer satisfaction guarantee the successful results which allowed us to grow from nearly thirty years.

## **PROJECT MANAGERS** CUSTOMER CONTACTS



**Luca Rossi**  
Direttore



**Susanna Forloni**  
Jewel in the crown



**CUSTOMER** ALWAYS  
DEALS WITH THE  
**COMMERCIAL STAFF**

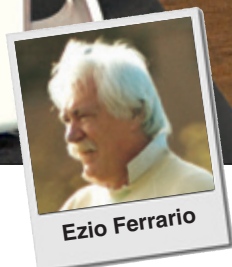

Ezio Ferrario



Alberto Delle Donne



Luigi Folcia



Stefania Piizzi

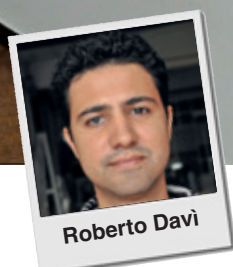

Roberto Davi



Federica Maggi



# PRE-PRESS PHOTOLITHOGRAPHY IMAGE FACTORY

**TOPCOLOR** takes care the pre-press, photolithography and graphics for more than thirty years, offering to customers the best digital technologies and top quality services for graphic creation of any kind of image in digital format.

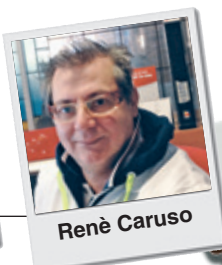



# PHOTOGRAPHIC LABORATORY ▶

**LAMBDA** 127 cm input,  
**EPSON 11880** 160 cm input,  
**Durst P10** 250 cm input.

**For Artists / Galleries / Museums**

In photography, **fine art** is synonymous with technical skill and quality. Our **fine art** laboratory not only aims to sell photography as art, it has also the duty of ensuring that this art and its beauty help to charm those who admire its content. This is possible by using top quality equipment and printing materials.

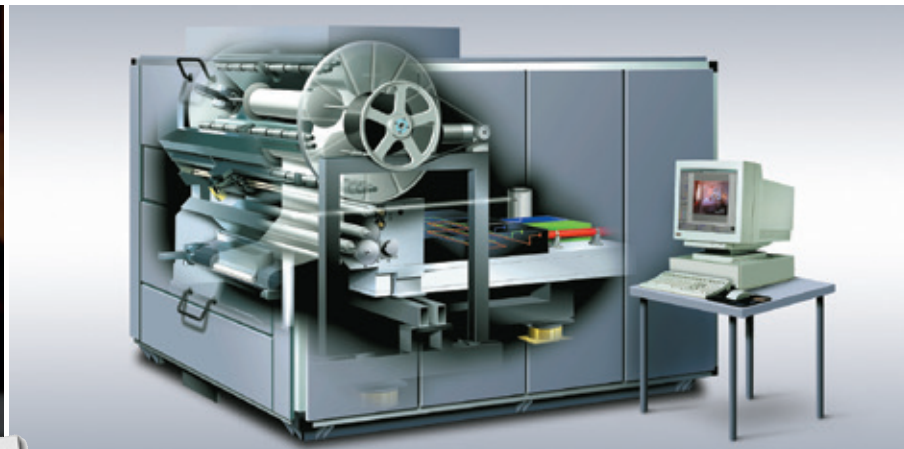

← **DIRECT CONTACT**

for order and quotes

☎ **+39 338 8433116**



# TOPSEC

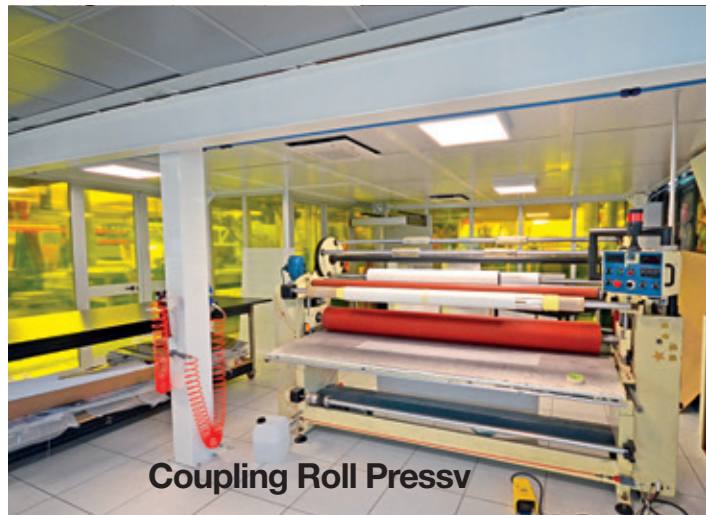
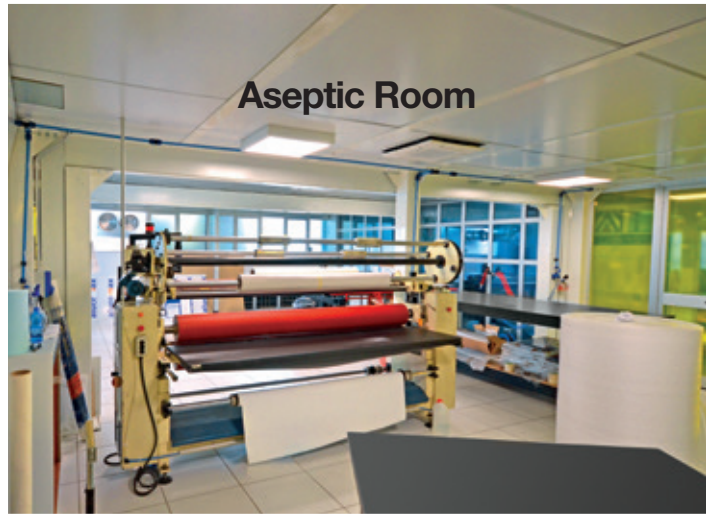

L U X U R Y TOPCOLOR

In the TOPSEC process two liquid components adhere to surfaces without using glues, forming a sandwich with the photographic print between two rigid materials (such as transparent acrylic/Persepx on the surface of the photograph and dibond on the back). TOPSEC enhances the colour contrast, enhances the most undetectable details, giving the images completely new size and intensity. TOPSEC also protects photographic images from scratches, dirt and prevent alterations. The anti UV surface protects printing from atmospheric agents and contaminations in the air. TOPCOLOR DREAM has so created a pristine processing sector “free from powders” with restricted access to specific staff only.



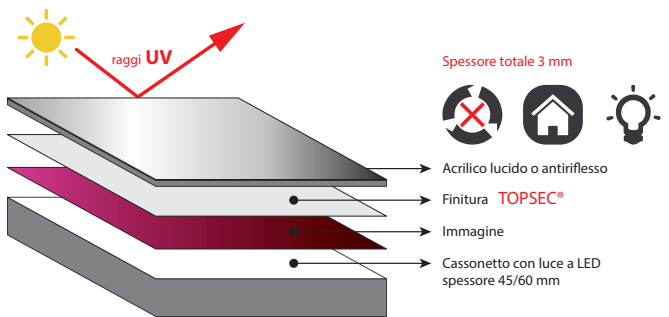
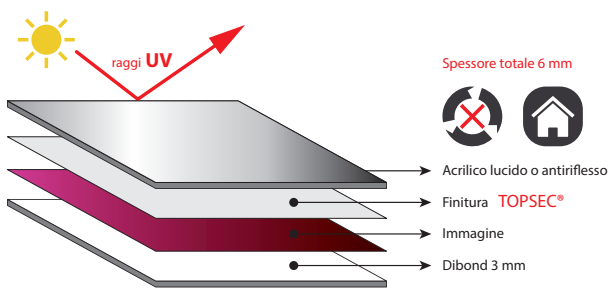
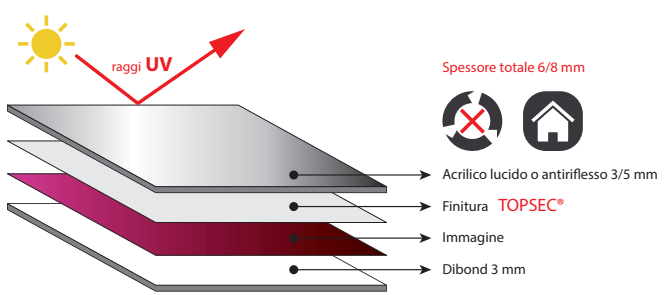
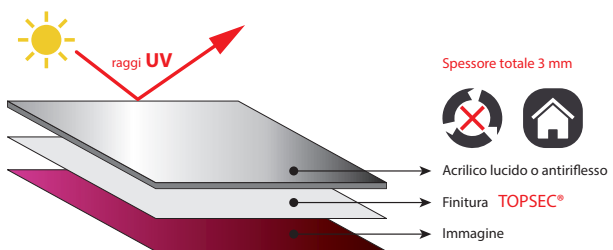



-  Processo irreversibile
-  Uso interno
-  Lightbox illuminata

Formato massimo realizzabile cm. 160x300



**FINE ART &  
LAMBDA  
EPSON 11880  
Durst P10**

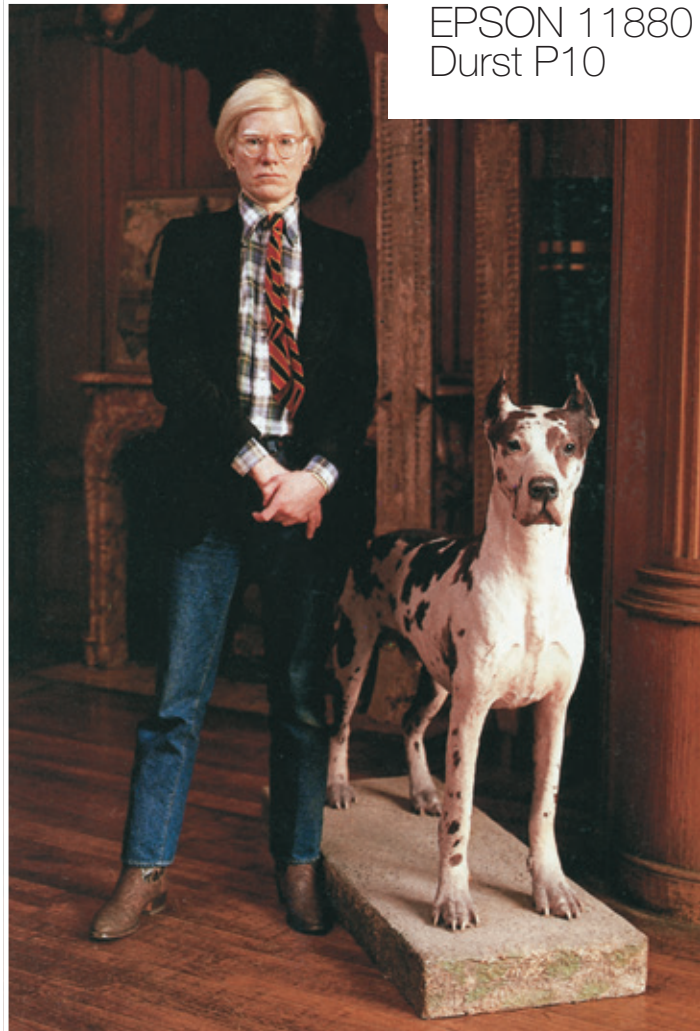

## FLATBED UV PRINTING **DURST RHO P10/250** 2,50 mt input

**With the smallest existing drop!  
32 heads for colour printing + 4 heads for white.  
OFFSET QUALITY**

The RHO P10/250 inkjet printer is the most versatile and productive 10 picoliter UV printer with the highest dependability available on the market (for round the clock production). The latest new Durst Quadro Array 10 print head technology allows this machine to offer unrivalled print quality. It was designed to guarantee a level of quality that allows a perfect close-up viewing of a wide range of promotional and advertising materials. From **signage** for indoor and outdoor use, to P.O.P. materials, up to backlit luxury items, the series P10 printer guarantees new business opportunities thanks to its unrivalled versatility and productivity.



 Printed products GREENGUARD Indoor Air Quality (IAQ) at low chemical emissions. This product has been certified according to Durst Phototechnik AG Rho Rotolo 30DM inks. These products are also recommended to customise hospital and children's rooms.



**Luca Rossi**  
Executive Director

**DIRECT CONTACT**



for orders and quotes  
**+39 340 3350345**



Mario Ratti



Alessandro Giuliani



Raffaele Massa



## FLATBED UV PRINTING **DURST RHO P10HS** 2 mt input

### With combined drying technology **TRADITIONAL + UV LED LAMPS**

The Rho P10 HS is a high speed version of the P10 250.

It is equipped with Quadro Array 10M printheads with double nozzle compared the Rho P10 250. It also has a drying system that combines traditional UV lamps and LED. It ensures the same high quality but with double speed printing.

The LEV drying process allows perfect drying sealing drops before the ink dries completely.

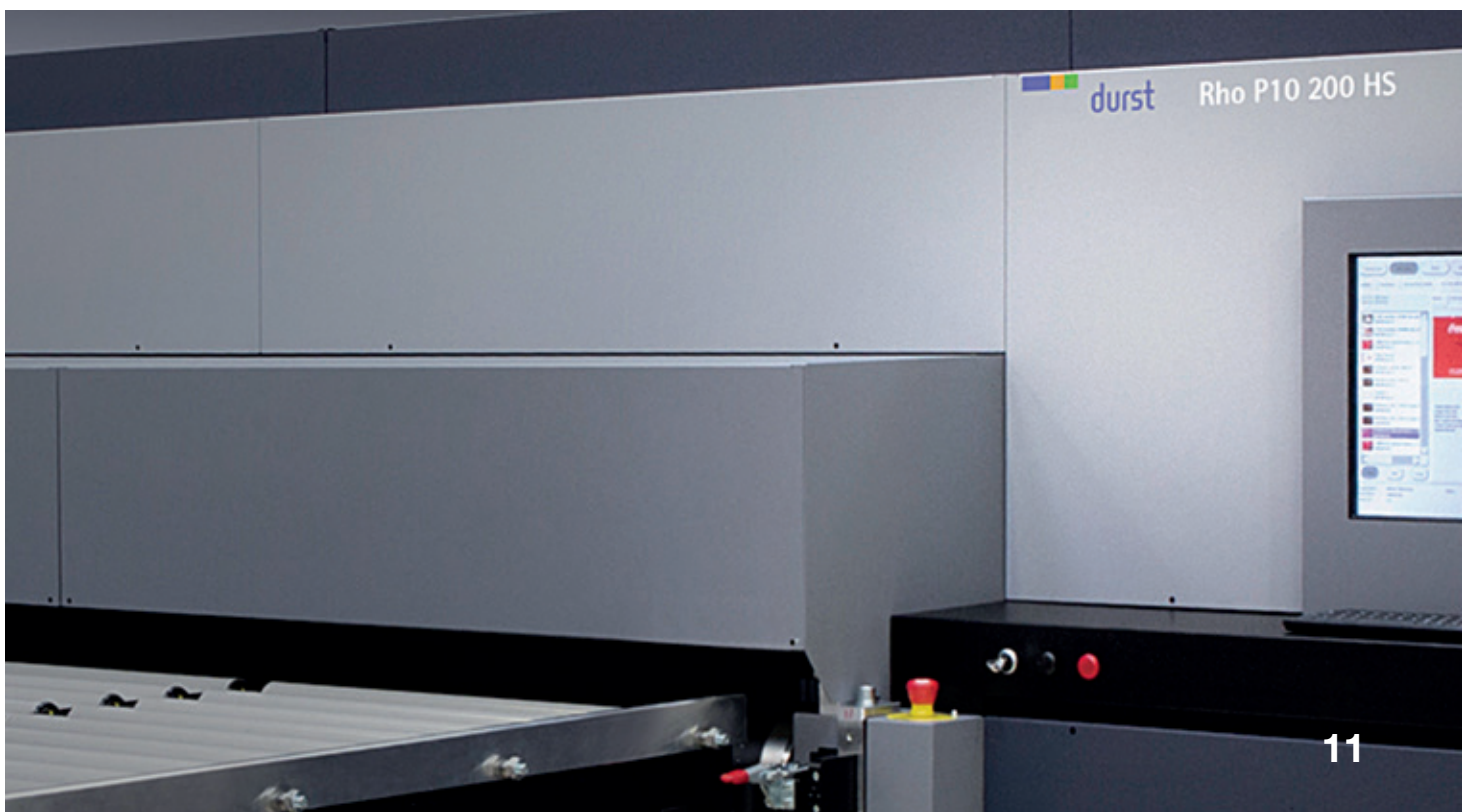

# ALL DURST



Printed products GREENGUARD Indoor Air Quality (IAQ) at low chemical emissions.  
This product has been certified according to Durst Phototechnik AG Rho Rotolo 30DM inks.

These products are also recommended to customise hospital and children's rooms.

## FLATBED UV PRINTING **DURST RHOPAC** 2 mt input

An industrial flatbed UV printer that can print up to 205 cm width, complete with a guide system for productive printing of corrugated cardboard and all other rigid and flexible materials.

The technical features of this machine are:  
5 colours (CMYK + White), print heads with patented Durst Quadro Array 50 technology.  
Resolution of 400/600 dpi print selectable.





# ROLL-TO-ROLL PRINTING



SUPER-WIDE **ROLL-TO-ROLL INK**  
12 picolitres with Variodrop technology

The **first** machine of its KIND installed IN ITALY



# 12 PICOLITRES OFFSET QUALITY



Mario Ratti



Davide Paglia



Alessandro Giuliani



Juriy Baruffaldi

# INKJET UV PRINTING **DURST RHO 512R**



Printed products GREENGUARD Indoor Air Quality (IAQ) at low chemical emissions.  
This product has been certified according to Durst Phototechnik AG Rho Rotolo 30DM inks.  
These products are also recommended to customise hospital and children's rooms.



The Rho 512R sets the new quality standard for productivity of high end industrial inkjet printers.

This is made possible by innovative Durst Quadro Array 12M print head technology, which produces drops measuring only 12 picolitres. This allows unrivalled print quality with a resolution up to 900 dpi and a maximum productivity of 350 m<sup>2</sup>/hour. The Rho 512R is perfect for printing a wide variety of large advertising materials, and can print three 1.6 m rolls wide at the same time.

The great precision of its conveying system, its linear motor, powerful Quadro Array technology and a print head with more than 30,000 nozzles allow this machine to achieve excellent print quality without reducing productivity.





---

STAMPA **ROLL-TO-ROLL**  
**EPSON 11880**  
1.6 mt input



Very high quality set of K3 8-color ink for printing photographic and fine art on a wide range of fine papers.

STAMPA **ROLL-TO-ROLL**  
**SEIKO H-104S**  
2.5 mt input

Printing technology with solvent inks and printheads piezoelectric SEIKO H-104S provides perfect prints on flexible materials such as PVC banners and vinyl stickers.



# CUTTING PLOTTER

## **ZÜND G3** 3,2x6 mt with automatic sheet feeder

We use the most complete, advanced version of the Zünd cutting and milling plotter, the only one installed in Italy with a useable work surface of 320x320 cm plus 160 cm entry and exit extensions increasing total size to 640x320 cm, with an automatic sheet feeder for non-stop production.



Raffaele Massa



Luca Brivio



Alexandru Andoni



# CUTTING PLOTTER

## **KONSBERG XP** 2x3 mt

We also have a Kongsberg XP 2000x3000 plotter. This means we have both of the most important cutting plotters on the market today. Complementary to the technical properties and cutting capacity of the Zünd, our Kongsberg is fitted with a 1Kw cutter with fluid cooling for unrivalled cutting speed and capacity, as well as all the fixed and vibrating blade tools for paper and card processing.



# CUTTING PLOTTER

## **PROTEK UNICO TT** 2x3 mt with milling cutter liquid cooled 4KW

TOPCOLOR installs UNICO and lands in Europe! Protek Unico TT, accuracy, productivity and perfect reliability. Protex Unico is capable to perform work that other systems cannot do. It allowed us to automate and improve the accuracy of the creation of a product we recorded as TOPSEC. It was possible by the 12 positions for tool change, 4KW milling cutter and 5 suction pumps.

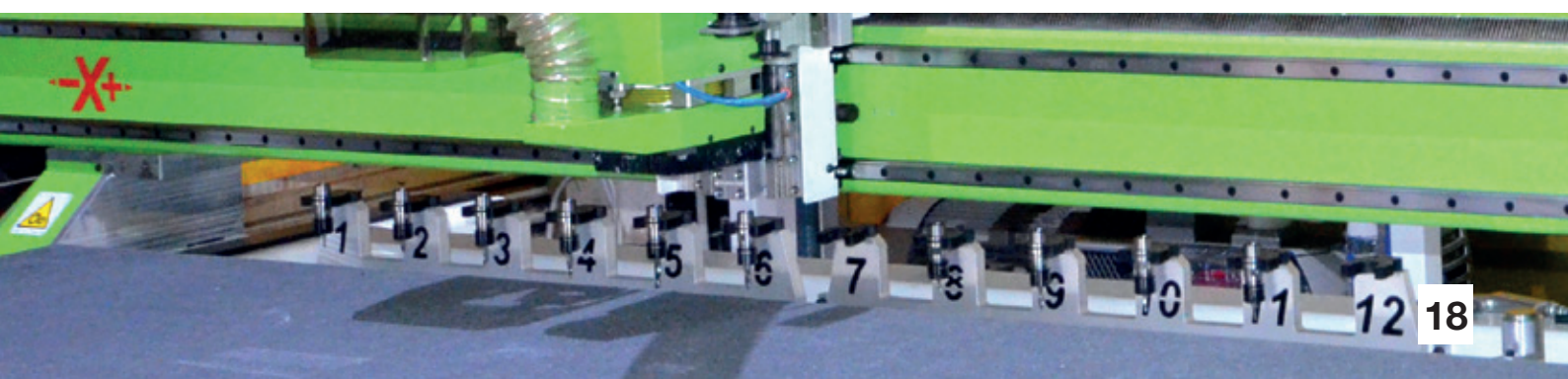





## PRINTER **HP INDIGO PRESS 3050**

Small size digital printing for business cards, brochures, flyers, pamphlets and small runs of little books.

- Paper size 320x464 mm.
- Printable size 305x440 mm.
- 4 colours + white
- Substrates from 80 to 350 g.
- Mould-made, coated, embossed, synthetic, special, adhesive, and other papers.



for orders and quotes



**+39 335 1358369**



**Marco Guerra**  
Responsabile



**Christian Gattarello**

# PRINTER

## **KONICA MINOLTA PRESS C8000**

- With online folding and saddle crimping station.
- Paper size 330x483 mm.
- Printable size 320x470 mm.
- 4 colours.
- Substrates from 70 to 350 g.
- Mould-made, coated, synthetic, adhesive and other special papers.





FINISHING  
**DUPLO SYSTEM 5000**  
With in line square backbone



Fully automatic folding and stapling station. Implemented with 10-pocket input collection tower, automatic inside binding trim, square binding adjustable in multiple ways to allow metallic saddle stitching even on very large pages, while giving the printed material a perfect look.

FINISHING  
**DUPLO MULTIFUNCTION  
DC 645**

With in line DC F2 folder

Cutting, trimming, creasing and folding station. It allows single or multiple processing of each paper sheet. Fully automatic with input sheet feeder and output tray. It allows the passage from “machine sheet” to finished product without manual actions.



---

# DIGITAL **SHEET** PRINTING

Today the world is spinning too fast, the breakeven point with offset printing has been reduced and there is no longer need to print thousands of catalogues which will end up in a dusty warehouse and eventually they will be thrown away.



Unusable because obsolete, aged



Everything in order, always updated

With digital printing sheet you can print your leaflets, brochures and catalogs in fewer copies, more frequently and you will have:

- **Your product always up-to-date**
- **Less waste and less time consuming**
- **Stock level at the minimum**
- **Your Brand and your products will never get old!**



## Traditional paperback



Text and images must be paginated taking into account the fold.

## Spiral



The cards are completely separate, and we must consider the holes for the spiral.



With the new binding **Flat-Book** you are no longer bound to the format, you can keep the texts in the crease.

**TURN THE PAGE AND YOU WILL SEE ....**

# Flat-Book®

LIBRO PIATTO

The binding **Flat-Book** enhances the presentation because it allows the perfect opening of the pages. You can place images in double page always maintaining a perfect vision.



## GREAT COMFORT AND AESTHETIC RESULT

### NO MORE FOUR-PAGES FOLDERS

With **Flat-Book** you no longer need to work in signatures and insert 4 pages if 2 are enough!

It is achievable with any number of pages and you can also create detachable tabs or different weight from the rest of the project.



---

# PLEXIGLASS WORK

Our facilities to work with plexiglass, such as a tabletop cutter, hot bending machine, U.V. gluing station , hydrogen flame for polishing formed rims and diamond-tipped cutter for polishing straight rims. This allows us to produce freestanding and countertop plexiglass display units, including moulded units.

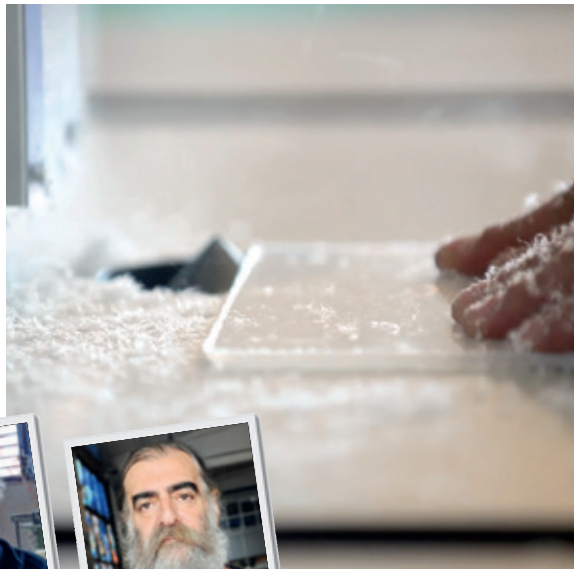
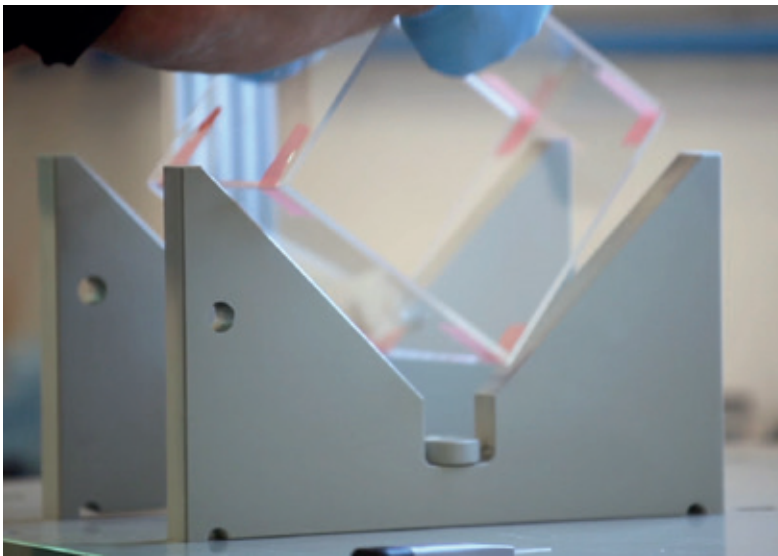

Alberto Locati



Luigi Marrani

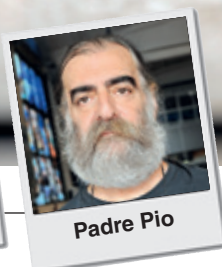

Padre Pio

# PAPER & CARD & PACKAGING

We design and create countertop and freestanding permanent and temporary display units, structures and boxes for packaging directly in response to our customers' requests and according to their specific needs. We use the best CAD design and 3D rendering programs for paper and card available on the market.

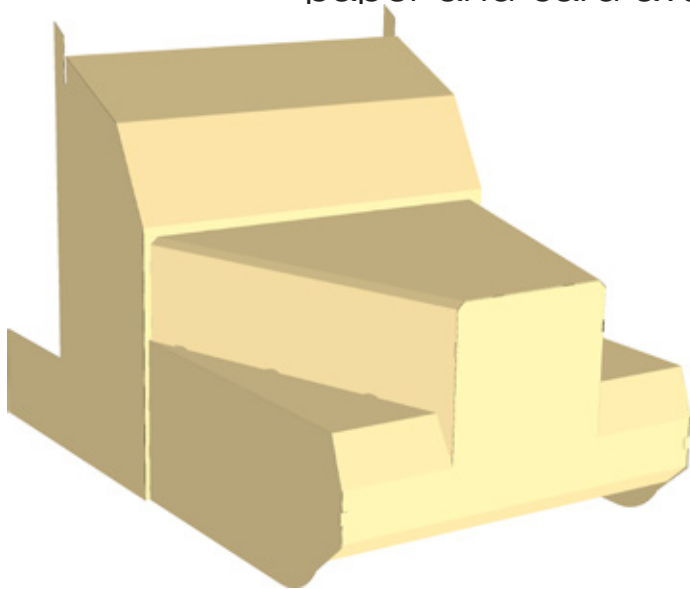
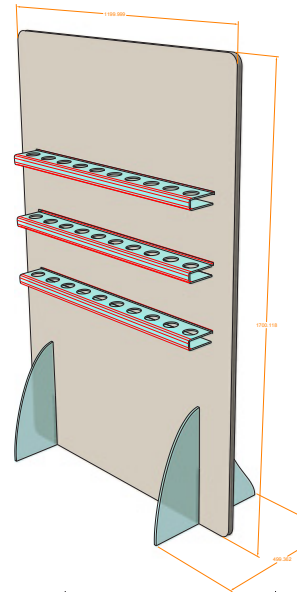

Cliente: *Coca-Cola*  
 Articolo: Portacalendari  
 Cartone: Reboard 10 Mq Scatola: 4.66

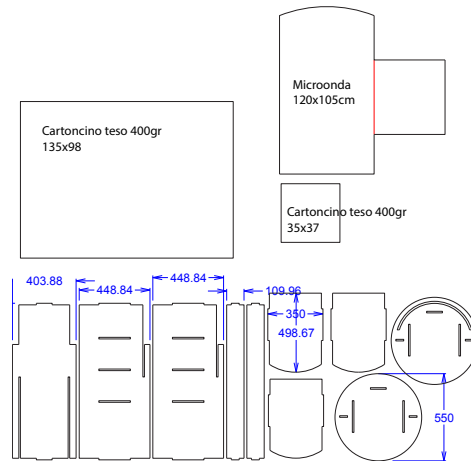

**DIRECT CONTACT**

**334 6418455**

**Roberto Davì**  
Responsabile

**Federica Maggi**

**Coca-Cola  
Christmas sleigh**





Disegno n°:	<b>Cliente:</b> <i>Coca-Cola</i>	Lungh. Lama: 30.67 m.
Disegnatore: Roberto	<b>Articolo:</b> Vassoio con crowner	Lungh. Cordoni: 14.2 m.
19-03-2012	Cartone: Microonda Mq Scatola: 4.265	Totale Filetti: 44.87 m.
		Dir. fibra: orizzontale
		Dim.int. mm:

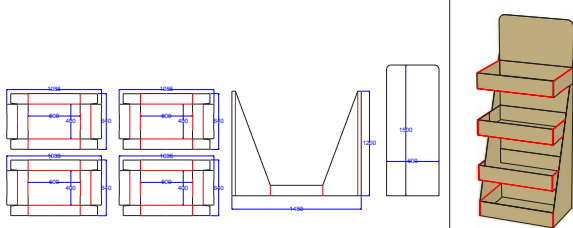

**TOPCOLOR DREAM**



**PAPER & CARD**  
& PACKAGING

**"INNAMORATO  
PAZZO DELLA  
TECNOLOGIA  
FACILE"**

**IN  
EDICOLA!**

STORIE IDEE E PERSONE CHE CAMBIANO IL MONDO  
**WIRED**

CondèNast Editions  
Launches WIRED magazine



**Copri-pallet Natalizio  
Coca-Cola**





Fiera di Rimini SiaGUEST 2014



# MUSEUMHOME

## BOISERIE MURALE

Smooth, matt, glossy or plastered wood.

A Topcolor group company,  
e-commerce division for online sales.



### e-commerce

900 subjects in the  
catalog viewable in  
low resolution on  
our site  
[www.museumhome.it](http://www.museumhome.it)

**CHOOSE  
AND  
ORDER**

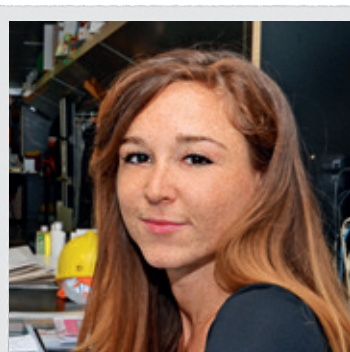

**Arch. Sara Reale**  
direct contact  
**+39 3356254944**



# [www.museumhome.it](http://www.museumhome.it)



**Composizione Boiserie Murale**

**Composition Boiserie Murale**

**ISTRUZIONI FACILI PER L'APPLICAZIONE**  
**EASY INSTRUCTIONS FOR APPLICATION**

**MUSEUM HOME**  
IL *museo* DI CASA TUA

Artista: **Giovanni Domenico Tiepolo**  
(Zianigo, 30 agosto 1727 - Venezia 3 marzo 1804)  
Opera "**Il Casotto dei saltimbanchi**"  
Formato finale: **281x343cm** in undici pezzi

Questa stampa dimostrativa in B/N verrà fornita con ogni soggetto  
This demo print in B/W will be supplied with each subject

**BOISERIE MURALE®**



Sample technical data sheet



Boiserie Murale size:

**281x343 cm.**

The work was taken apart into eleven panels and packed in a small box so it could be shipped anywhere in the world. The fresco is easy to apply following the instructions.

# UV LACQUERING ELMAG

## AN ALTERNATIVE TO THE ROLLING PRESS

We do have a coating line for the protection and enancement of digitally printed materials which creates a protective layer of U.V. paint on request. Maximum working size: 3000x1300 mm

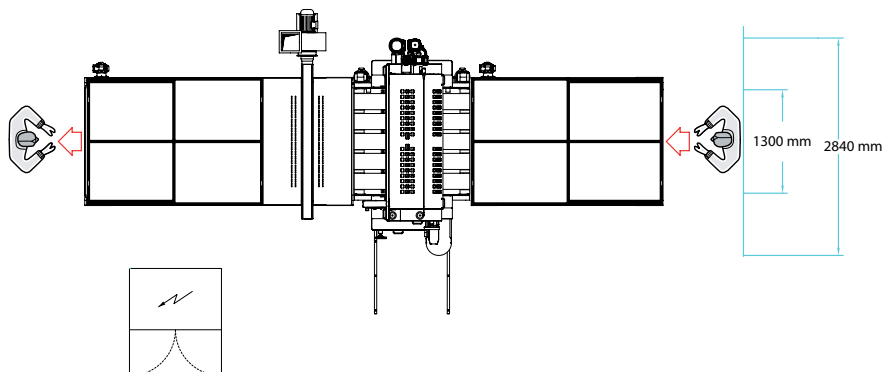

AVOID ALL THE BUBBLES that could occur with the protection by using roll pressed film, due to thermal excursion day/night summer/winter.



Padre Pio



Gilberto Barzon



---

## **MINOR** CARPENTRY for **PACKING**

## **PAINTING** STATION

We have a small carpentry to build rigid packaging for shipment by courier, and a painting station to meet the most particular requirements.

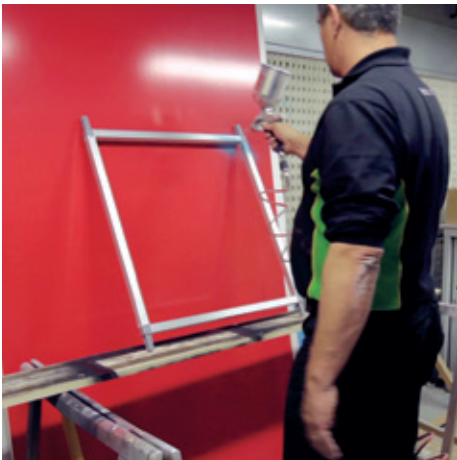

## MEC-PACK STX **PACKING MACHINE**

A fully automatic shrink film packing machine for packing even large quantities of panels, to respond to urgent requirements of all kinds.



# OUR VEHICLES FOR DELIVERY AND INSTALLATION

A fleet of 5 vehicles and a team of 3 workers to install and set up your projects, all Topcolor employees.

Topcolor employees operate under a health and safety management system conforming to D.L. 81/2008





MILANO

TOPCOLOR



## HALL AND CONVENTION CENTER AUDITORIUM OF EXPO



**Project:** BROS. THE DOORS. Collage. Environmental dimension. EXPO Milano 2015

**Print:** TOPCOLOR 8000 square meters. (the largest work of the entire event)

**Material:** adhesive vinyl **mactac** outdoor matt laminate





# MALESIA PAVILLION

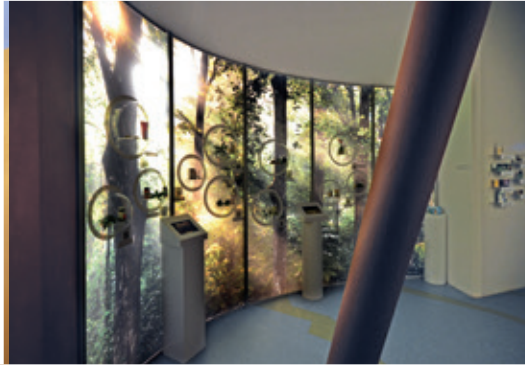

# CAMBOGIA PAVILLION



# BRUNEI PAVILLION





# THANK OUR PARTNERS

---



durst

EPSON  
EXCEED YOUR VISION

Kongsberg  
ESKO



ZÜN  
swiss cutting systems

Hahnemühle  
FINEART

Certificati **gms**<sup>color</sup>

# TOPCOLOR DREAM

STAMPA DIGITALE A CICLO COMPLETO

**TOPSEC**  
LUXURY TOPCOLOR

FineArt

MUSEUM  
HOME  
IL *museo* DI CASA TUA

**BM**<sup>®</sup>  
BOISERIE  
MURALE



Printed products GREENGUARD Indoor Air Quality (IAQ) at low chemical emissions.  
This product has been certified according to Durst Phototechnik AG Rho Rotolo 30DM inks.  
These products are also recommended to customise hospital and children's rooms.

[www.topcolor.it](http://www.topcolor.it)

**WE PRINT ON ALL MATERIALS UP TO 4CM THICKNESS**

---

*A Company that  
deserves to be visited*

THIS CATALOGUE IS MADE  
WITH LEAF ON LEAF  
TECHNIQUE:



With the addition of ...

OLI DE GUMBET  milanese  
Milano

---

OLIO DI GOMITO  italiano

---

ELBOW GREASE  inglese

---



Printed products GREENGUARD Indoor Air Quality (IAQ) at low chemical emissions.  
This product has been certified according to Durst Phototechnik AG Rho Rotolo 30DM inks.

These products are also recommended to customise hospital and children's rooms.

**TOPCOLOR DREAM**

[www.topcolor.it](http://www.topcolor.it)

Via Toscana 19, 20090 Buccinasco,  
Milano +39 02.4886431  
cf/pi 05086400966

MUSEUM HOME  IL museo DI CASA TUA

SALE ON LINE AT:

[www.museumhome.it](http://www.museumhome.it)

Via Toscana 19, 20090 Buccinasco,  
Milano +39 02.4886431 / 48864339  
cf/pi 13433460154